

Safesite Mobile Man Anchor



INTRODUCTION

The CE Approved Mobile Man Anchor is an item of Personal Protective Equipment (PPE) which has been specifically designed to provide short term safety for low frequency operations where guardrails are not provided. The unit is ideal for short term maintenance operations to flat roofs or to the plant and equipment installed at roof level such as AC units, telecommunications equipment etc.

Safesite's Mobile Man Anchor is extremely compact, portable, easily assembled and features a unique design incorporating a shock absorber which reduces the total weight of the unit, making the product more "user friendly". The Mobile Man Anchor has been designed to be used with an approved shock absorbing rope grab and rope and full body harness to provide safe access at all times.

The unit is fully galvanised to BS EN ISO 1461:1999 Hot Dip Galvanised Coatings Specification and test methods. The Anchor Weights are supplied with suction cup rubber boots. These protect the roof membrane, increase friction resistance and enable the anchor to be used on all roof membranes, even in wet weather.

The Mobile Man Anchor fully complies with BS EN 795: Protection against falls from height - Anchor devices - Requirements and testing.

The unit has also been designed to ensure compliance with the following Regulations:

- Work at Height Regulations 2005
- Construction (Health, Safety & Welfare) Regulations 1996
- Construction (Design & Management) Regulations
- Workplace (Health, Safety & Welfare) Regulations 1992
- Manual Handling Operations Regulations 1992

BUILDING HEIGHT & SAFE WORKING

It is essential that a risk assessment is carried out by a competent person to ensure that the product is used safely. Part of the assessment will consider the building's height and the combination of PPE to be used in conjunction with the Safesite Mobile Man Anchor.

Safesite recommends that, as far as reasonably practicable, the Mobile Man Anchor should be used as a fall restraint solution rather than fall arrest. When used for fall restraint, the Mobile Man Anchor must be used in conjunction with PPE that prevents the

operative from reaching the leading edge. The Mobile Man Anchor should then be positioned so that the rope remains taught as the user approaches the edge.

If the above is not possible and a fall arrest solution is required then a sufficiently detailed risk assessment, method statement and rescue policy must be produced by a competent person. Care must also be taken to use the correct combination of PPE to minimize the distance & consequence of a potential fall.

Generally the length of the shock absorbing rope grab device should not exceed the height of the building in order to avoid the possibility of the pendulum effect. To prevent this, the Mobile Man Anchor should be placed perpendicular to the leading edge where the operative is likely to be working. The rope grab line should remain taught at all times when working at the leading edge.

No part of the Mobile Man Anchor should be placed closer than 2.5m from the nearest roof edge. The unit should not be placed on any surfaces affected by ice, grease or similar slippery conditions which may impair the performance of the unit.



see page 78

ROOF PITCH & SAFE WORKING

The Mobile Man Anchor can be used on any flat roof or industrial steel clad pitched roof up to 15° pitch provided that the unit is positioned on the opposite pitch to where the operative intends to work. When placed on a roof slope, the Mobile Man Anchor must be at least 2.5m from the ridge. In all cases, the roof structure must be capable of taking the load of the Mobile Man Anchor (250kg) combined with the weight of the operative, plus any additional equipment required.

LEGAL REQUIREMENTS

The Work at Height Regulations 2005 require that the employer/building owner has a rescue plan and policy in place for all fall arrest systems. (see pages 82-87)

TESTING & CE APPROVAL

Safesite's Mobile Man Anchor has been extensively tested by SATRA to BS EN 795: Protection against falls from a height - Anchor devices - Requirements and testing. The unit was tested on the following roof surfaces and has been awarded CE Approval accordingly.

Single Ply Membrane	Paving Slabs
HT Mineral Grade Felt	Asphalt
Swept Stone Chippings	Steel Cladding

EN 795 TEST PROCEDURE

The test involved a 100kg weight freefalling a distance of 2.5m to reach a maximum velocity. The Mobile Man Anchor then had to bring this force to a complete rest within a horizontal movement not exceeding 1.0m. This was achieved via the extension of the shock absorber coupled with horizontal movement of the complete unit. This test was then successfully duplicated using a 120kg weight. Full independent test documentation is available upon request.

In addition to the above testing, the Mobile Man Anchor has also been tested with a shock absorbing rope grab device with 14mm twisted rope connected to the shock absorber of the Mobile Man Anchor over steel & concrete sharp edges, thus representing on site usage of the system. The same test load as BS EN 795 was applied to the system. This testing successfully demonstrated the compatibility of the shock absorbing rope grab device with 14mm twisted rope when used horizontally in combination with a Safesite Mobile Man Anchor over sharp edges.

EN 795 REVIEW

This standard has recently been reviewed. As a consequence the 100kg test weight remains unchanged, but the free fall distance has been changed from 2.5m to 1.5m. Once this dynamic load has been applied an additional 100kg static load is then applied, thus representing an extreme rescue situation where a rescuer has no choice but to abseil to the casualty.

LINKED MOBILE MAN ANCHOR SYSTEMS

See Fall Arrest and Restraint Linked System on page 78

Safesite Mobile Man Anchor Specification

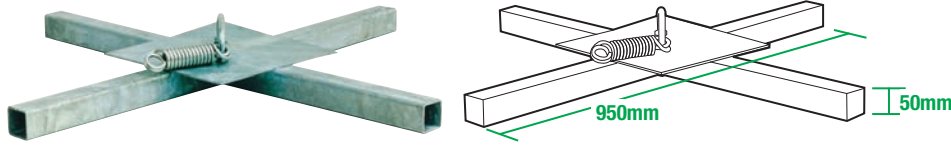

MOBILE MAN ANCHOR CROSS FRAME - MMA 001

This unit is the heart of the system and provides the means of connecting the man anchor weights to the shock absorber anchorage point. Material : galvanised steel to BS EN ISO 1461. Net weight : 13.6kg.

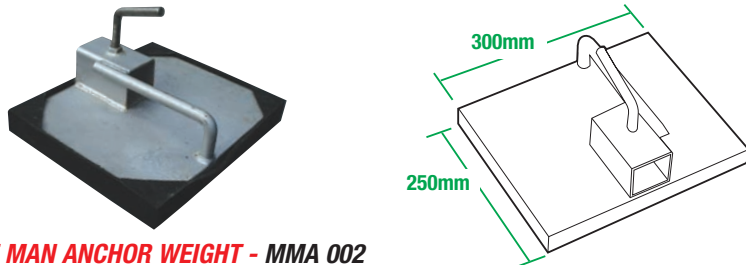

MOBILE MAN ANCHOR WEIGHT - MMA 002

This component is one of twelve that are used to provide the overall weight of the system. Material : galvanised steel to BS EN ISO 1461. Net weight : 19kg.

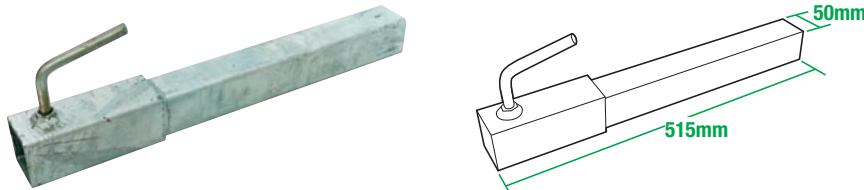

MOBILE MAN ANCHOR EXTENSION ARM - MMA 003

This unit is utilised to connect the second and third weight of each arm to the cross frame. Material : galvanised steel to BS EN ISO 1461. Net weight : 2.5kg.

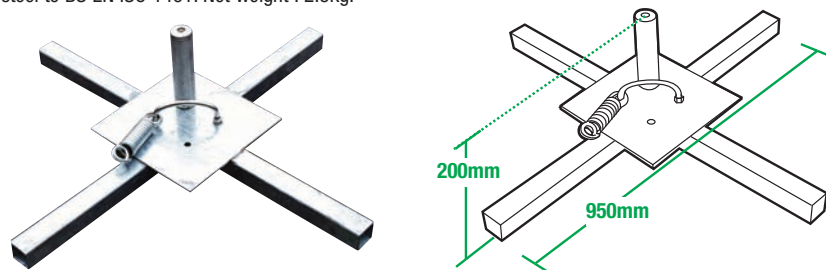

LINKED MOBILE MAN ANCHOR - CABLE SUPPORT POST - MMA 004

This item can be fitted to the standard cross frame. This arrangement links a series of Mobile Man Anchor utilising the Safesite horizontal line system. This provides a fall restraint/arrest system that has the advantage of being free standing as opposed to being traditionally fixed to the structure. Mobile Man Anchor centres 10m. Material : Mobile Man Anchor Cross Frame : galvanised steel to BS EN ISO 1461. Net weight : 13.6kg. Cable Support Post : Stainless steel AISI 316L grade. Net weight : 0.885kg. (This code relates to the Support Post ONLY, not the Cross Frame and Support Post.)

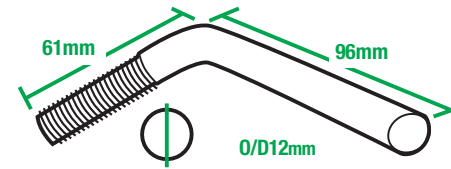

L-BOLT - MMA 005 & HANDLE - MMA 006

The L-Bolt provides the means of securing the components to the system. Material : stainless steel A2-50 grade. Net weight : 0.13kg. The Handle provides the attachment of the shock absorber to the Mobile Man Anchor Cross Frame. Material : stainless steel A2-50. Net weight : 0.285kg.

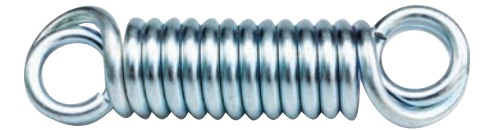
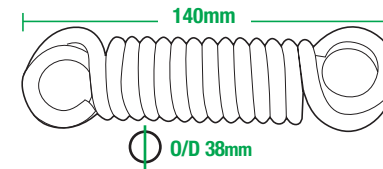
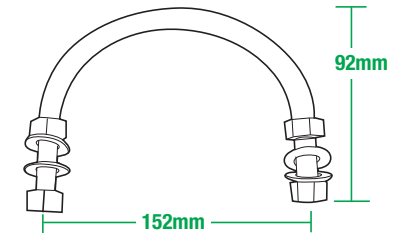

SHOCK ABSORBER - MMA 007

This component absorbs the shock loading should an operative fall whilst connected to the Mobile Man Anchor. The component is designed to be disposed of should it be activated. Material : bright zinc plated steel. Net weight : 0.85kg.

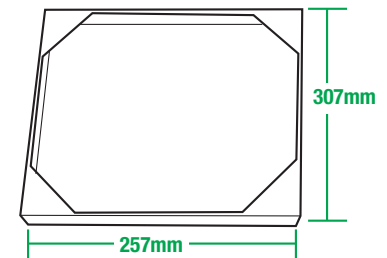
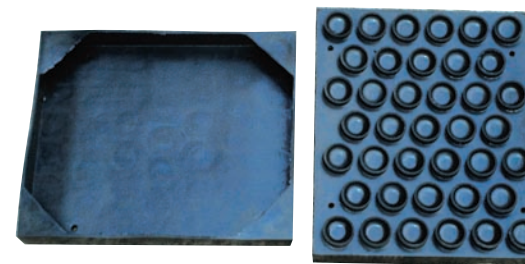

RUBBER BOOTS - MMA REP BOOTS

Set of 12 replacement rubber boots for MMA 002.

Complies with BS EN 795 Class E Anchorage Devices

MOBILE MAN ANCHOR USER INSTRUCTIONS

- Please ensure all operatives have read fully and understood all instructions for the safety equipment before using and completed a comprehensive risk assessment for each roof and/or roof membrane.
- Only one person to be connected at any one time.
- Recommended maximum weight of person 100kg.
- On a flat roof make sure that the Mobile Man Anchor will be used at least 2.5m from the edge of the roof. See diagram.
- See pages 30-31 for Minimum Height Requirements.
- When used on steel clad roofs up to 15° pitch always place the Mobile Man Anchor on the opposite pitch to the one you are working on. Always position the Mobile Man Anchor a minimum of 2.5m from the ridge on the opposite pitch. When working on the verge detail remember to position the Mobile Man Anchor at least 2.5m from the verge and only work opposite the Mobile Man Anchor in order to avoid the pendulum effect down the façade of the building.
- Sweep any loose materials from the surface of the roof covering where the Mobile Man Anchor will be placed. (Do not use on icy, greasy or any slippery surfaces that may impair the Mobile Man Anchor's performance.) Ensure that the rubber boots are in place and in good condition before using.
- Slide 1 Mobile Man Anchor Weight onto each of the cross frame legs and tighten the locking handles in a clockwise direction. See diagram for exact layout.
- Slide 1 Extension Arm onto each of the cross frame legs and tighten the locking handles in a clockwise direction. See diagram for exact layout.
- Slide a further 2 Weights onto each of the Extension Arms and tighten the locking handles in a clockwise direction. See diagram for exact layout.
- Connect karabiner (or similar approved clip) of the shock absorbing rope grab device (or fixed length lanyard) only to the loose end of the spring shock absorber on the Mobile Man Anchor.
- Never connect to any other part of the Mobile Man Anchor. Check the spring shock absorber is in good condition and that it is not stretched or damaged in any way. If the spring is elongated do not use the unit and return the whole assembly to Safesite Limited for repair / replacement.
- All operatives must read & fully understand all PPE instructions before using with the Mobile Man Anchor.
- Once the operative is wearing the harness connect the karabiner on the end of the shock absorbing rope grab device (or fixed length lanyard) to either of the chest or rear D-Rings of the harness.
- Make sure all connections are fixed correctly and that the system has been assembled correctly. The system is now ready for use.
- If you are in any doubt please contact Safesite's Technical Department on 01293 529977.

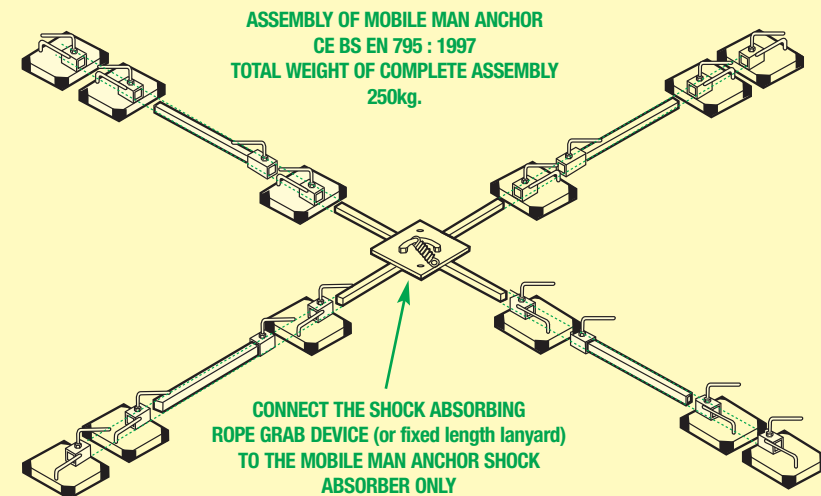
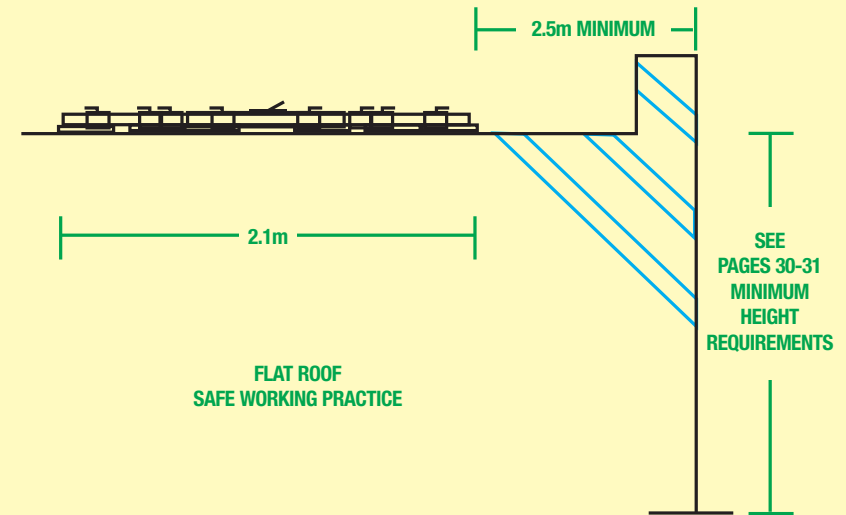

Safesite Mobile Man Anchor and Rope Grab Operation

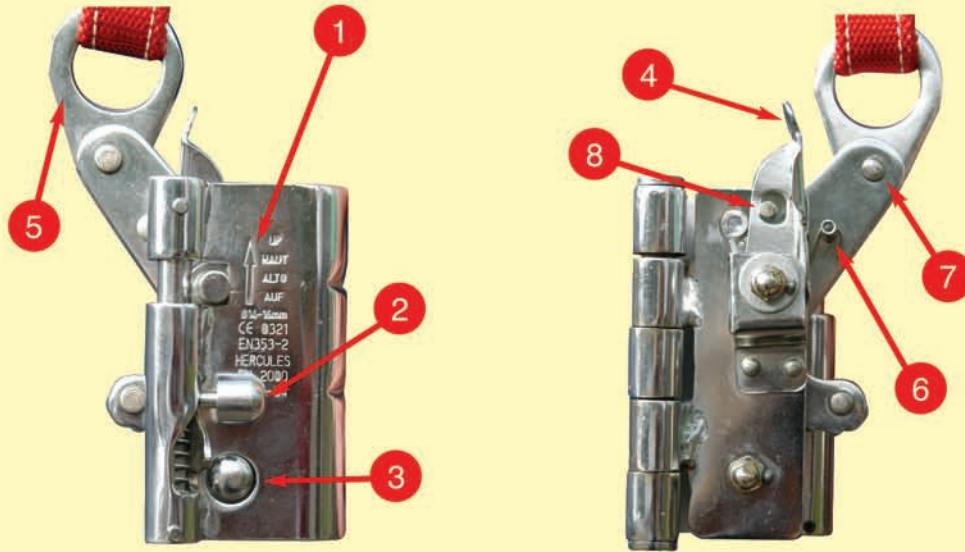

The rope grab has to be opened to position the rope correctly. Open the rope grab device as follows:-

Pull lever **2** down and push fully into the opening to disengage the pressure pin **3**. The device will now open. (Figures A, B & C)

Note:- Ensure the rope grab is attached to the rope with arrow **1** pointing towards the Mobile Man Anchor.

Place rope in the device, ensuring arrow **1** is still pointing towards the Mobile Man Anchor. Close the device and it will automatically lock. (The Lever will return to its original position). Check that the device slides freely on the rope when the eyelet **5** is pulled downwards. (Figures D, E & F)

Attach the end of the rope to the Safesite Mobile Man Anchor spring/shock absorber using an EN 362 connector. (Figure G)

The device can be used in either AUTOMATIC mode for use for vertical access (ladder) or MANUAL mode, when using along horizontal surfaces or inclined planes (roof).

MANUAL mode is the recommended option when using in conjunction with the Safesite Mobile Man Anchor on flat or inclined roofs.

When using in MANUAL mode, the selector **4** is down. Remove selector **4** from the securing pin **8** and bring it to rest against the end stop **6**. This will ensure that it can only slide along the rope by manually operating the pincher arm **7**. (Figures H & I)

In AUTOMATIC mode, selector **4** is up. In this position the device follows the user as they move upwards or downwards and, in the case of a fall, instantly locks on the rope. (Figure J).



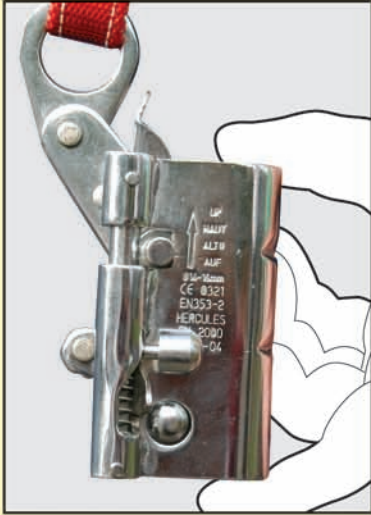

Figure A



Figure B

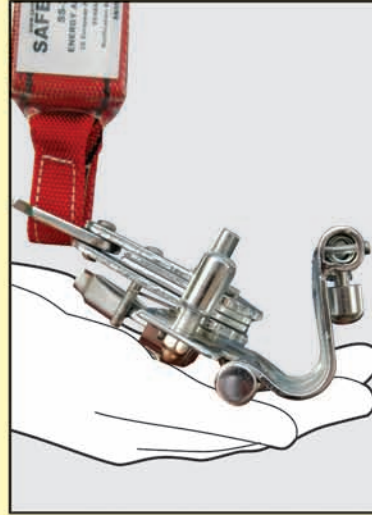

Figure C



Figure D

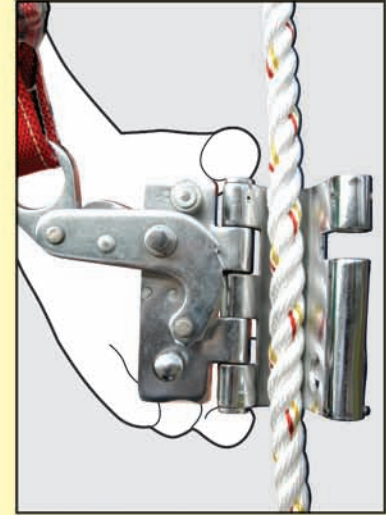

Figure E

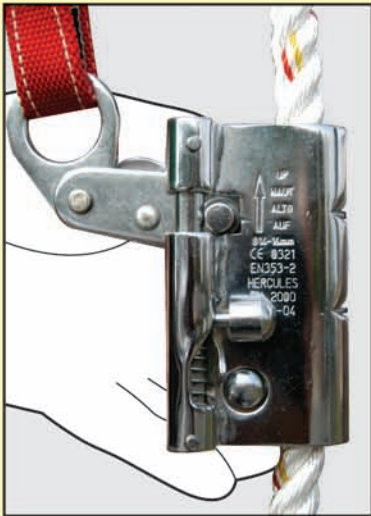

Figure F

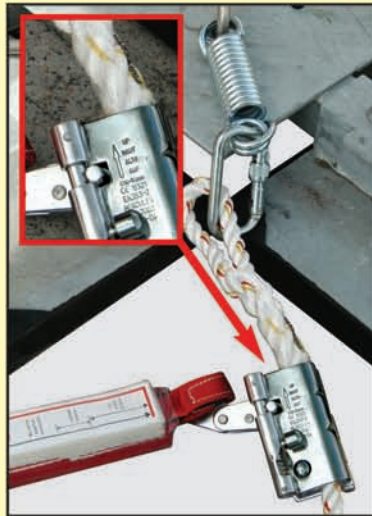

Figure G

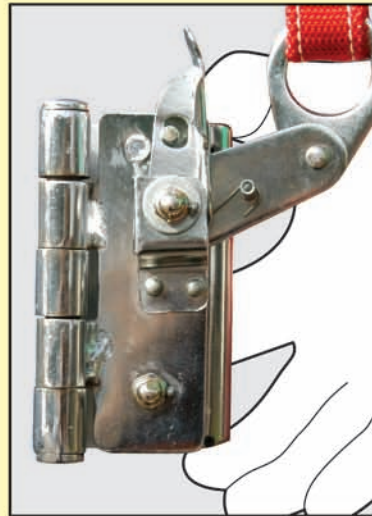

Figure H

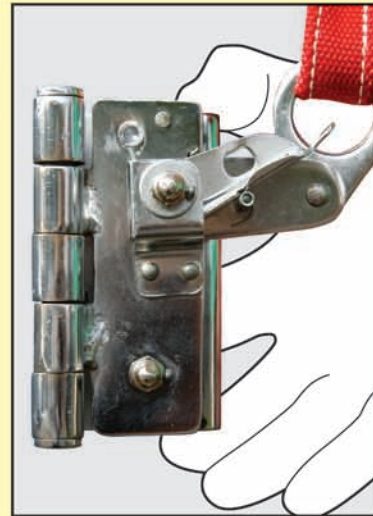

Figure I

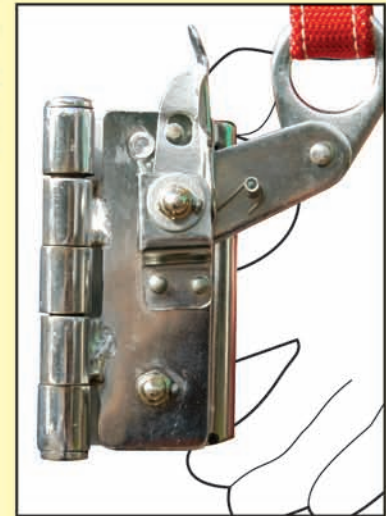

Figure J

Safesite Mobile Man Anchor Re-Certification

- Periodic inspections by a competent person are required under Regulation 5 of the Workplace (Health Safety & Welfare) Regulations 1992, BS EN 365 & BS 7883. The frequency will depend upon environment, location and utilisation, but should be at least every 12 months.
- Walk & visually inspect the complete system installation (where applicable) in relation to the general client's needs. Establish if any modifications, additional products are required to reflect any refurbishment or additional plant and equipment that has been installed and requires access.
- Check installation configuration (where applicable) is complete as per the original installation drawing/plan.
- Ensure the system has not been modified/tampered with by unauthorised persons.

DETAILED COMPONENT INSPECTION:-

Cross Frame (1).

- Check arms on cross for distortion or dents. Ensure that this does not affect the fitting of the weight or extension arm.
- Check metal plate for distortion or cracks.
- Check handle is securely in place.
- Check shock absorber for any signs of "pulling" - no elongation.
- Check for any general corrosion.

Extension Arms (4).

- Check arms for distortion along length.
- Ensure that any dents at widest end do not affect the connection to the cross frame.
- Look for signs of cracks in metal - especially around any "bruised" areas.
- Check for any general corrosion.

Counter weights (12)

- Check all rubber boots on the weights are in good order - no tears or rubber missing.
- Check L-bolts are still present and in good order to lock and unlock (ease of movement). ENSURE GREASING IS CARRIED OUT ANNUALLY.
- Check box section and handle for dents, cracking etc. Make sure arm slides through easily and is secure when L-bolts are tightened.
- Check for any general corrosion.
- Any galvanised components showing signs of corrosion, wire brush thoroughly and apply galvanised spray / paint as appropriate.
- If rusted significantly take digital photographs and include in inspection report.
- Once all other inspection points are completed, check that the whole device is fixed securely in position with no obvious distortions in balance.
- Check system plaque (where applicable) position & mark up to reflect date of the next required inspection. Establish if additional plaques are required due to any refurbishment works.
- In the event of a fall the Mobile Man Anchor MUST be returned to the manufacturer for re-testing.
When used in anger the shock absorber on the mobile man anchor will elongate as soon as this is observed the device MUST be taken out of service until re-certificated by the manufacturer.

NOTE: A Dynamic Risk Assessment must be completed by a competent person before the Mobile Man Anchor is used.

Safesite Mobile Man Anchor Re-Certification

Rubber Boot (12)

- The rubber boot on the anchor weight is paramount to the product's safety and performance and must be checked on a regular basis
- If the boot shows any sign of damage it must be replaced otherwise the product's frictional resistance will fail dramatically.
- Safesite's rubber boots can be retrofitted to the anchor weights to restore friction.
- These boots have been extensively tested in both wet and dry conditions, making Safesite's Mobile Man Anchor the only such product that can be used on all roof types, even in wet weather, without adding further anchor weights.



Pictured Above: Old style bonded rubber.



Pictured Above: New Rubber Boot, redesigned for improved performance on wet surfaces.